

SPC 1000 SERIES

SOLID PHENOLIC CORE LOCKERS



P.O. BOX 4090 • ONTARIO, CA 91761 • (951) 727-8600 • (951) 727-8612 FAX • WWW.IDEALOCKERS.COM

SPC 1000 SERIES

SOLID PHENOLIC CORE LOCKERS



SPC 1000 Series Solid Phenolic Core lockers are the material of choice when a high degree of design flexibility is desired, or where durability and strength are required. These lockers are fabricated to stand the test of time. The dense components, combined with stainless steel fasteners, stand up to the most extreme conditions of moisture and humidity.

Phenolic is impact, water and corrosion resistant, and does not support bacteria. The superior construction, and materials used in the locker system make it adaptable to all types of facilities, including health clubs, country clubs, and executive washrooms. Phenolic lockers can easily be customized. Now available in color-thru phenolic colors upon request.



[LEARN MORE](#)

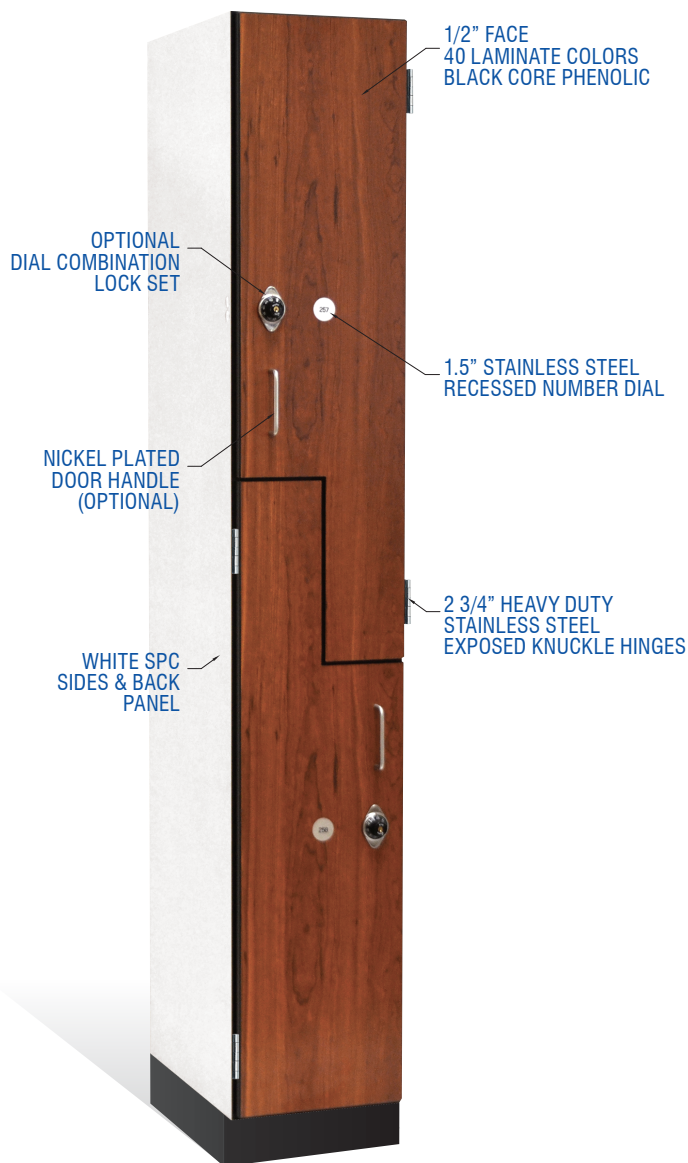

FEATURES

- For wet-use areas including pools and recreation centers
- 1/2" tops, bottoms and shelves, speckle tone Black Core Phenolic
- 1/2" face, 40 colors, Black Core Phenolic
- 3/8" sides and back, speckle tone Black Core Phenolic
- 1/4" Full perimeter ventilation rear panel
- 1-1/2" Stainless steel recessed number dial
- Double prong ceiling hung coat hooks
- White Solid Phenolic Core interior
- Self latching door
- Confirmat® fastener
- Fully assembled single unit construction
- 180 degree opening stop stainless steel 5 knuckle exposed hinge
- Padlock hasp, and accepts built in locks
- Slope tops, finished (colored) end panels and fillers available
- Graffiti resistant, permanent marker easily removed
- Does not support bacteria
- 10 year warranty

LOCKER DIMENSIONS | 12"x18"x72" SPC, DC, EH

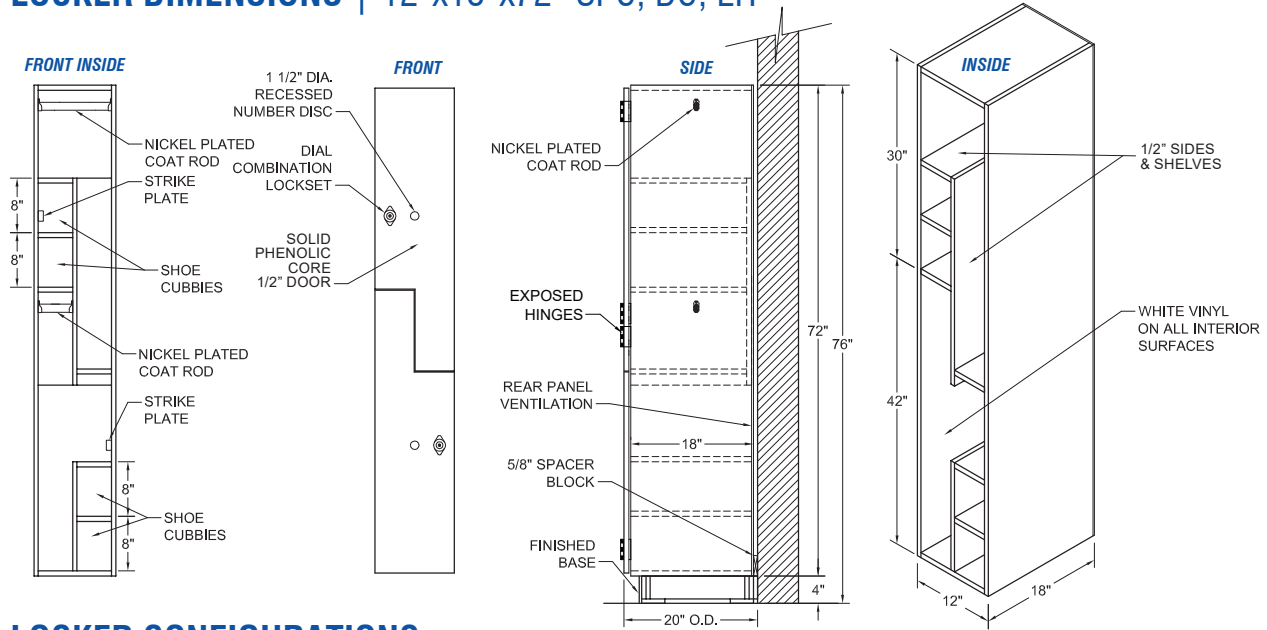

LOCKER CONFIGURATIONS

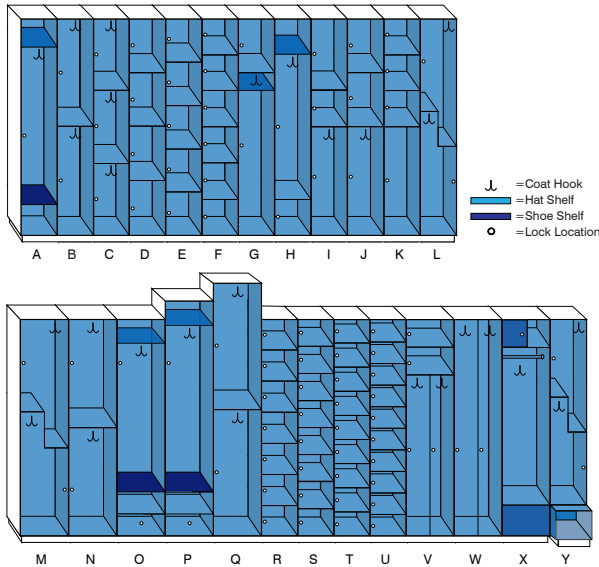

ITEM	DESCRIPTION	WIDTH	DEPTH	HEIGHT
A	One Tier	12"	18"	72"
B	Standard Two Tier	12"	18"	72"
C	Three Tier - Gymbag	12"	18"	72"
D	Four Tier	12"	18"	72"
E	Five Tier	12"	18"	72"
F	Six Tier - Purse Size	12"	18"	72"
G	Modified Two Tier	12"	18"	72"
H	Modified Two Tier	12"	18"	72"
I	Modified Three Tier	12"	18"	72"
J	Modified Three Tier	12"	18"	72"
K	Modified Four Tier	12"	18"	72"
L	Executive Style Two Tier	12"	18"	72"
M	Executive Style Two Tier	16"	18"	72"
N	Standard Two Tier	16"	18"	72"
O	Tennis Club	16"	18"	72"
P	Country Club	16"	18"	78"
Q	Maxi-space	16"	18"	84"
R	Seven Tier	12"	18"	72"
S	Eight Tier	12"	18"	72"
T	Nine Tier	12"	18"	72"
U	Ten Tier - Sneaker	12"	18"	72"
V	Vertical Quad Tier	16"	18"	72"
W	Vertical Two Tier	16"	18"	72"
X	Epicenter	16"	18"	72"
Y	3000 Series Model "L"	12"	18"	72"

PRODUCT SPECIFICATIONS

- Frame Components**
 - Solid Phenolic with melamine surface both sides produced with resin impregnated materials.
 - Locker frame constructed of solid phenolic core Class IIB fire rated doors, sides and shelves=1/2" Back=1/4").
 - Interior horizontal surfaces of shelves, tops and bottoms are finished with white Solid Phenolic Core materials.
- Frame Construction** = Blunt joint, 2" t-head nail and screw.
- Edging**
 - Frame and door edges are black, beveled and polished.
- Hinges**
 - 1000 Series includes heavy duty, 304 stainless steel 180 degree opening 2 3/4" exposed five knuckle hinges (EH).
- Doors** = 1/2" Solid Phenolic Core with beveled and polished edges.

AIA SPECIFICATIONS

SECTION 10500 - SOLID PHENOLIC CORE LOCKERS.

Requirements of Divisions 0 and 1 apply to work of this section.

1.0 GENERAL

1.1 SCOPE OF WORK INCLUDED

- A. The furnishing and installation of prefabricated AWI Type I multiple self-supporting modular fire resistant, custom grade, SOLID PHENOLIC CORE lockers.

1.2 RELATED WORK SPECIFIED ELSEWHERE

- A. Architectural Woodwork - Section 06400
 B. Wood and Plastic Doors - Section 08200
 C. Wood and Plastic Windows - Section 08210

1.3 STANDARDS

- A. Minimum standard for fire resistant, SOLID PHENOLIC CORE lockers shall conform to ARCHITECTURAL WOODWORK STANDARDS latest edition.

1.4 QUALITY ASSURANCE

- A. All parts and hardware shall be AWS compliant, structurally sound and free from defects, in material and workmanship under normal use and service for a period of three (3) years. All lock parts warranted for a period of one (1) year by the respective manufacturer.

1.5 SUBMITTALS

- A. Submit two copies of AWS compliant shop drawings for all items of finish work before fabrication.
 B. Manufacturer's descriptive data of all materials and products construction, overall dimensions for installation of lockers, accessories, and trim.
 C. Submit 3 color samples of solid phenolic core specified.

1.6 PRODUCT HANDLING, DELIVERY & STORAGE

- A. Deliver all lockers when project construction is ready for installation. Store lockers in dry, ventilated area and protect all finishes from soiling and damage during handling.

2.0 PRODUCTS

2.1 GRADES

- A. Furnish SPC 1000 Series furniture grade solid phenolic core lockers in accordance with ARCHITECTURAL WOODWORD STANDARDS.

2.2 ACCEPTABLE MANUFACTURER

- A. Ideal Products, Inc. PO Box 4090, Ontario, CA 91761.

2.3 MATERIALS

- A. Locker exterior:
 Solid Phenolic with melamine surface both sides produced with resin impregnated materials at pressures exceeding 1000 psi, at 256 degrees resulting in a solid, dense, water resistant product. All edges to be black.
- B. Locker interior:
 1. Interior vertical surfaces of sides and back panel are finish white solid phenolic core materials.
 2. Interior horizontal surfaces of shelves, tops and bottoms are finished with white Solid Phenolic Core materials.
 3. Locker frame constructed of solid phenolic core Class IIB fire rated doors, sides and shelves=1/2" Back=1/4").
 4. Frame and door edges are black, beveled and polished.
 5. Locker venting through rear panel 32mm system.
- C. Doors, End Panels, and Sloped Tops: 1/2" Solid Phenolic Core with beveled and polished edges.

2.4 HARDWARE

- A. Hinges, heavy duty, 304 stainless steel 180 degree opening 2 3/4" exposed five knuckle (EH).
 B. Locks, heavy duty:
 1. Padlock hasps either recessed (RP) or surface (SP) mounted through-bolted with 3/4" dia. zinc plated t-nuts and 10/20 x 3/4" machine screws; case hardened and cadmium plated steel.
 2. Campadlock hasp. Specify chrome or brass finish?

3. Keyed Locks, two keys per lock and master keyed. Specify chrome or brass finish? 1500KD (KL).

4. Dial combination with changeable codes and master keyed bypass (DC).

5. Pushbutton combination with over 2000 different combinations. Specify satin chrome or satin brass? (PC)

6. Coin Collection (CC), Coin (CR) or Token Return (TR) and Card Operated (CL).

7. Digital Locksets for Temporary (ATS) or Permanent Usage (APS) – Nickel Finish.

- C. Clothes hooks, aluminum:

1. Ceiling hung double pronged.
 2. Side mounted double or single pronged (Optional).

- D. Coat Rods, nickel plated (Optional).

- E. Number Disc 1 1/2" recessed, 3/8" numerals 304 stainless steel. Specify numbering sequence?

2.5 FABRICATION

- A. Lockers shall be fabricated using blunt joint, nail and screw joinery.
 B. Fabricate lockers square, rigid, and without warp.
 C. Machine all parts and attachment holes accurately and without chips.
 D. Fabricate corners, fillers, scribes, tops as required for installation.

3.0 EXECUTION

3.1 CONSTRUCTION

- A. Conform to requirements of AWS ARCHITECTURAL WOODWORK STANDARDS, latest edition, for joinery requirements using blunt joint and Confirmat® screw construction.

3.2 INSTALLATION

- A. Install lockers at the locations shown in accordance with manufacturer's instructions for plumb, level, rigid and flush installation.
 B. Lockers are easily installed on a standard prefabricated 4 x 17 x 72" unfinished bases per locker room layout, cut to fit as required, level bases using readily available shim shingles.
 C. Hang wall straps 75 1/2" inches above bases, spaced approximately 4 to 5 feet apart.
 D. Stack lockers one next to the other per plans, allowing approximately 24" separation in corners, bolt each from together using manufacturer supplied fasteners through predrilled holes. Be sure to align leading edges of locker frames with each other as fasteners are tightened.
 E. Install end and corner fillers and caps, cut to size in field per plans.
 F. Install end panels.
 G. Install number discs, clean lockers, remove all related trash and debris from job-site.

3.3 CLEAN-UP

- A. Upon completion of the work, remove surplus materials, rubbish and debris resulting from the operations under the section, including equipment and implements of service, and leave the entire structure and site insofar as the work of this section concerned in a neat, clean, and acceptable condition.

3.3 WARRANTY

- A. Ideal Products, Inc. warrants its Phenolic Lockers, properly maintained, against delamination, breakage or corrosion for 10 years from the date of receipt by the customer. If materials are found defective during that period for the reasons listed above, the material will be replaced free of charge.
 No credits or allowances will be issued for any labor or expenses related to the replacement of components covered under the warranty plan. All such expenses are to be borne by the buyer.

Ideal Products, Inc. reserves the right to change/modify specifications at any time.

ORDERING INSTRUCTIONS

Example:

SPC 1000 Series, Model B, 12 x 18 x 72", SPC, DC, EH,
 1 2 3 4 5 6

- 1 Specify SPC 1000 Series for Solid Phenolic Core Lockers. 1000 Series includes (SE) Self-Edging and (EH) Exposed Knuckle Hinges.
 2 Select the style and size locker compartment such as Model B, our standard double tier or Model F, our purse size lockers.
 3 Confirm the frame dimensions: Width x Depth x Height.

- 4 Select Solid Phenolic Core and choose any color or combination of colors.
 5 Specify Locks. (RP) = Recessed Padlock Hasp, (PC) = Pushbutton Combination, (DC) = Dial Combination, (CL) = Card Lock, (CO) = Coin-Operated, (CC) = Coin-Collect, (KL) = Keyed.
 6 Specify Hinges. (EH) = Exposed Knuckle.

LOCKER ROOM DIAGRAMS

GENERAL NOTES

- Locker to be standard as manufactured by Ideal Lockers.
- $\frac{5}{8}$ " spacers edged with matching edging to allow for hand clearance.
- Single end panels $18\frac{5}{8}$ " wide to cover rear ventilation.
- Double end panels $36\frac{5}{8}$ " wide to allow for air space.
- Fillers are required.
- TLW (total locker width) = Total number of lockers x locker width.
12" lockers are 12.0625" wide; 16" lockers are 16.0625" wide.
- Consult factory for requirements.

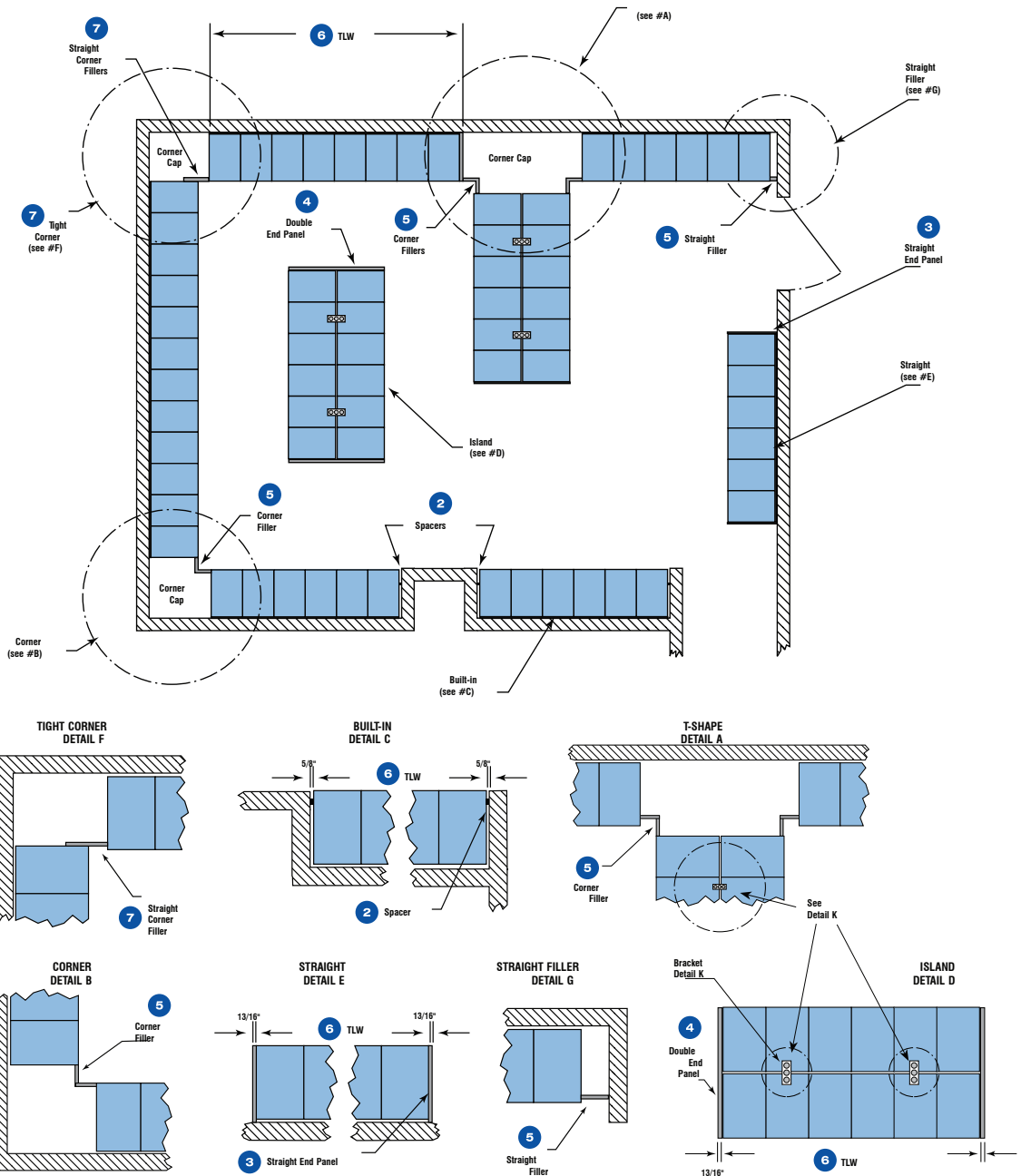

HANDICAPPED OPTIONS

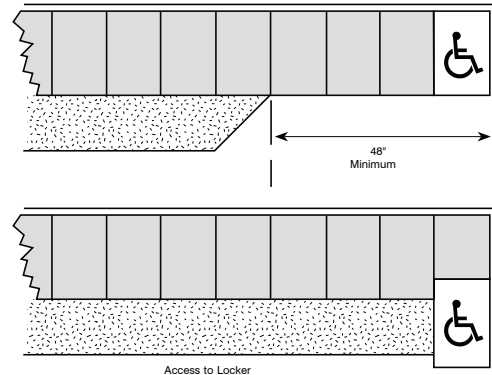
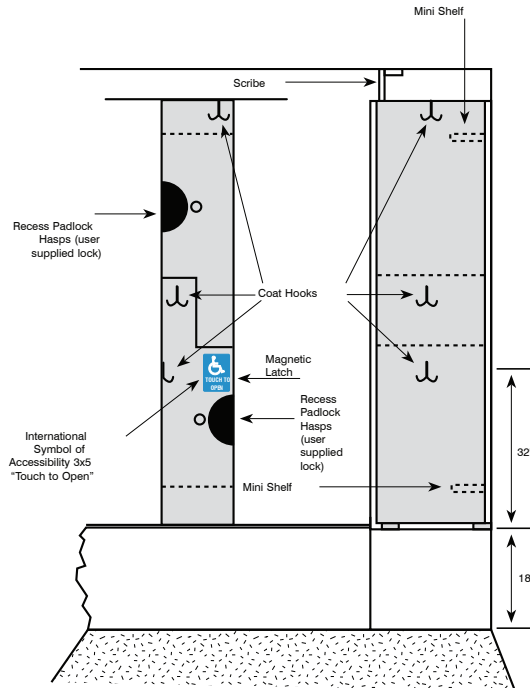

Local building officials will eventually require your clubs to comply with The Americans with Disabilities Act of 1990 which requires the following: At least one of each type locker offered, and for double-tier lockers only the bottom row, be provided for handicapped people. A clear floor space of 30"x48" minimum will allow for either forward or parallel approach by a person using a wheelchair. Storage spaces such as shelves, hooks, coat rods, etc., shall be located at a height of 9" minimum and 48" maximum from the finished floor. Acceptable hardware for accessible lockers are touch latches and U-shaped pulls located as close to the top of the door as possible.

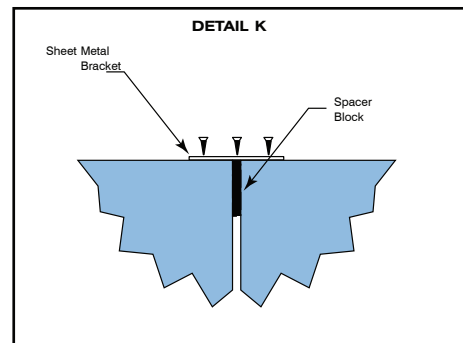
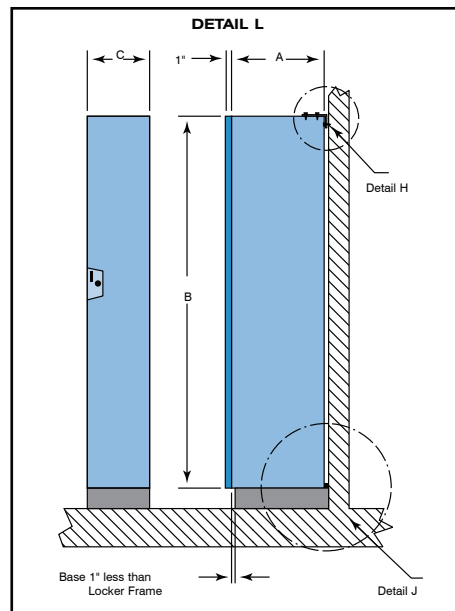
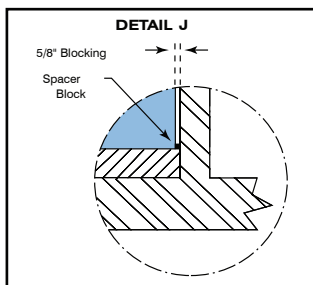
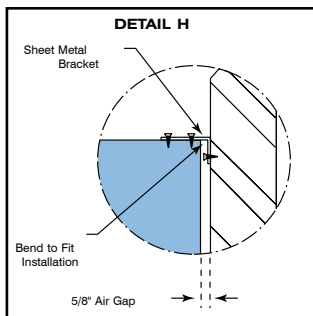



Ideal PRODUCTS, INC.